

Specifications

Sealing Mechanism: Welded Bellows
Material Exposed to Vacuum: Stainless Steel
Bakeout Temperature: VUF: 450°C, -SF: 200°C

Operating Temperature: -20° to 230°C
Pressure Range:
 VAC-U-FLANGE®: Atmosphere to 1×10^{-11} Torr
 SPEED SYSTEM: Atmosphere to 1×10^{-9} Torr

THIS DRAWING IS THE PROPERTY OF HUNTINGTON MECHANICAL LABS, INC., AND IS PROPRIETARY IN GENERAL AND IN DETAIL. IT SHALL NOT BE MODIFIED IN ANY WAY. PERMISSION IS GIVEN TO PRINT AND DISSEMINATE FREELY.

VF-177-275 Series

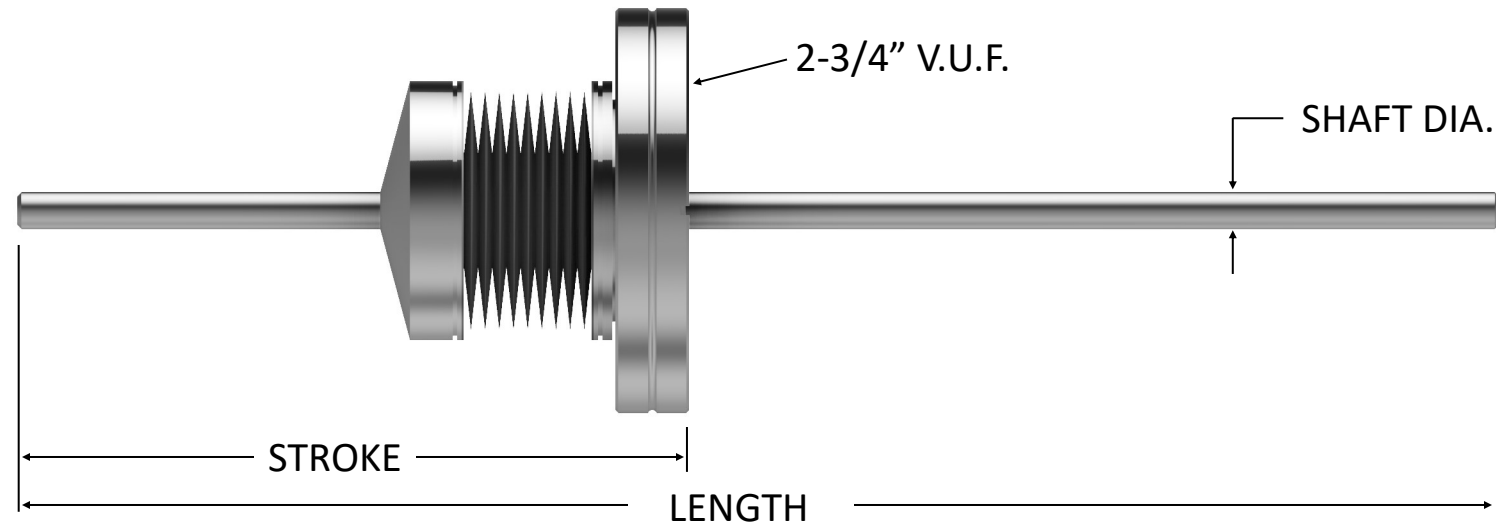

VF-177-133 Series

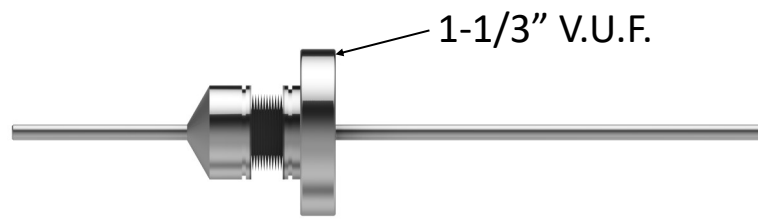

VF-177-275-SF Series

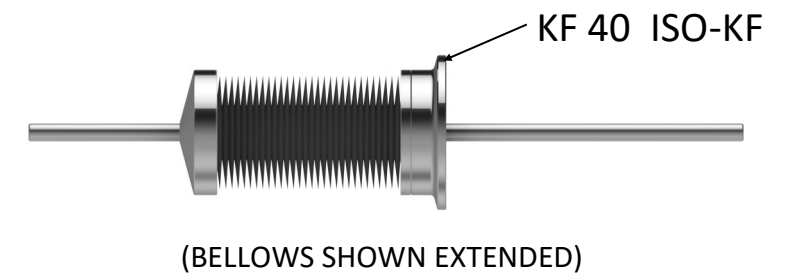

VF-177-133-SF Series

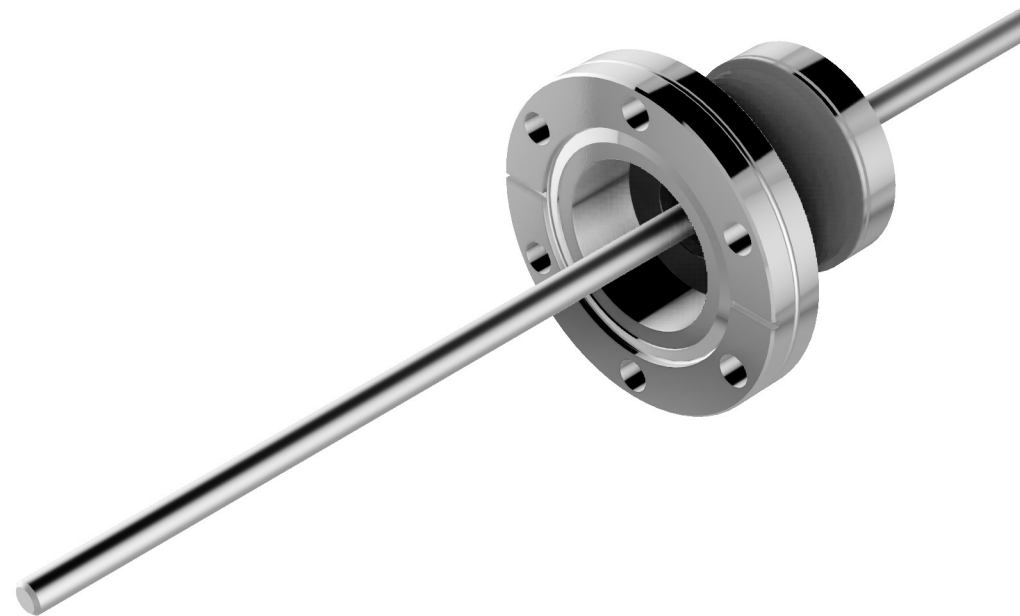
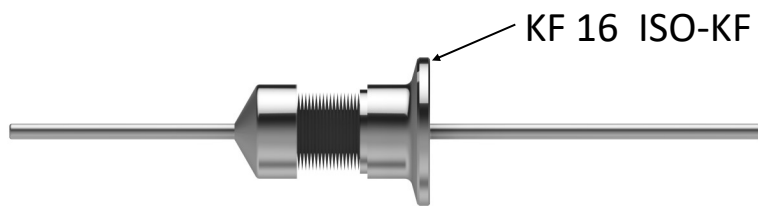

Dimensions: inches (mm)

LINEAR / ANGULAR WOBBLE STICK

FLANGE	SHAFT DIA.	STROKE	LENGTH	ANGULAR MOVEMENT	WEIGHT (lbs.)	PART NUMBER
1 1/3"	.125	0.21 (0.53)	6.00	44° TOTAL	1.0	VF-177-133
2 3/4"	.250	0.80 (2.03)	10.0	60° TOTAL	3.0	VF-177-275
KF 16	.125	0.21 (0.53)	6.00	44° TOTAL	.75	VF-177-133-SF
KF 40	.250	0.80 (2.03)	10.0	60° TOTAL	2.5	VF-177-275-SF

Other stroke lengths & flange options available. For quotes, please call 800-227-8059 or visit our website at www.huntvac.com. Email: vacman@huntvac.com

		13355 NEVADA CITY AVENUE GRASS VALLEY, CA. 95945
WOBBLE STICK, LINEAR/ ANGULAR, US STD.		
B	DWG. NO. VF-177-XXX-(SF) OUTLINE	REV. -
SCALE: NO SCALE	SHEET: 1	OF 1