

**Specifications**

**Sealing Mechanism:** Welded Bellows  
**Material Exposed to Vacuum:** Stainless Steel  
**Bakeout Temperature:** 200°C (Maximum)  
**Operating Temperature:** -20° to 150°C  
**Pressure Range:** Atmosphere to  $1 \times 10^{-11}$  Torr

**Position Lock:** Thumb Knob  
**Maximum Axial Load:** 10 lbs. (4.5 kg) concentric load  
**Maximum Lateral Load:** 20 lbs. (9.1 kg) @tip in ret. position  
**Scale Resolution:**  
 Linear: 0.05" (1 mm)  
 Micrometer: .0001" (.002 mm)

THIS DRAWING IS THE PROPERTY OF HUNTINGTON MECHANICAL LABS, INC., AND IS PROPRIETARY IN GENERAL AND IN DETAIL. IT SHALL NOT BE MODIFIED IN ANY WAY. PERMISSION IS GIVEN TO PRINT AND DISSEMINATE FREELY.

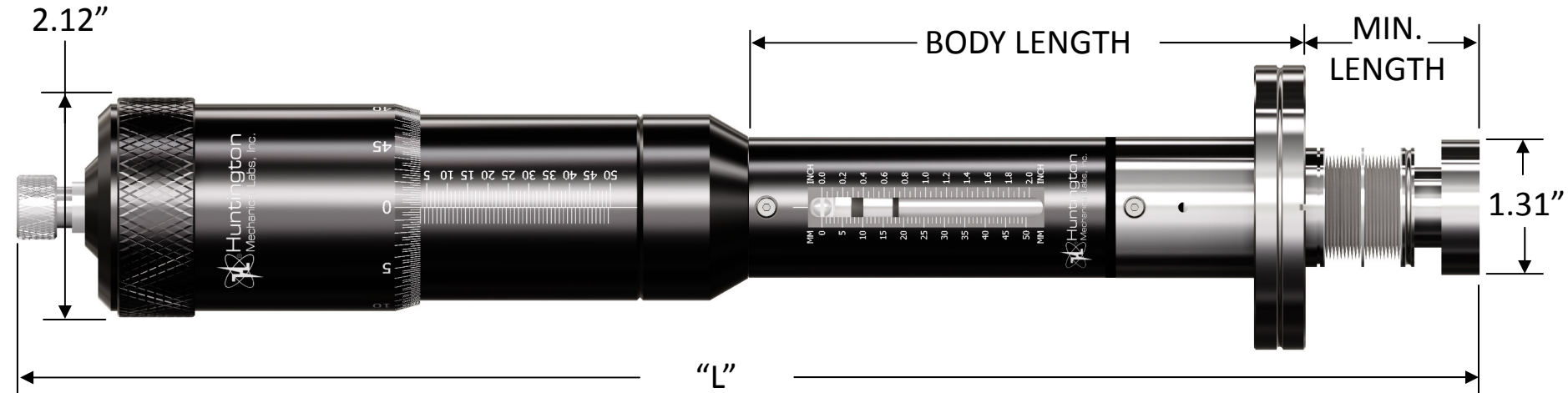

L-2241-X-SF Series



END VIEW

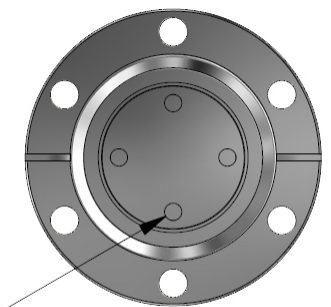

10-32 UNF - 2B  
x 4 @ 1.00 B.C.

Dimensions: inches (mm)

**L-SERIES MANUAL LINEAR w/MICROMETER**

FLANGE	STROKE	BODY LENGTH	LENGTH "L"	MINIMUM LENGTH	WEIGHT (lbs.)	PART NUMBER
2 3/4"	1.0 (25.4)	4.38 (111.3)	10.89 (276.6)	1.30 (33.0)	3.5	L-2241-1
	2.0 (50.8)	5.38 (136.7)	14.24 (361.7)	1.68 (42.7)	4.0	L-2241-2
KF 40	1.0 (25.4)	4.38 (111.3)	10.89 (276.6)	1.30 (33.0)	3.1	L-2241-1-SF
	2.0 (50.8)	5.38 (136.7)	14.24 (361.7)	1.68 (42.7)	3.8	L-2241-2-SF

Other stroke lengths & flange options available. For quotes, please call 800-227-8059 or visit our website at [www.huntvac.com](http://www.huntvac.com). Email: [vacman@huntvac.com](mailto:vacman@huntvac.com)

		13355 NEVADA CITY AVENUE GRASS VALLEY, CA. 95945
<b>FEEDTHRU, LINEAR, 2200 SERIES                  MICROMETER, US STD. W/SCALE</b>		
B	DWG. NO. L-2241-X-(SF) OUTLINE	REV. -
SCALE: NO SCALE	SHEET: 1	OF 1