

Specifications

Sealing Mechanism: Welded Bellows
Material Exposed to Vacuum: Stainless Steel
Bakeout Temperature: 200°C (Maximum)
Operating Temperature: -20° to 150°C

Pressure Range: Atmosphere to 1×10^{-11} Torr
Position Lock: Hand Knob
Maximum Axial Load: 25 lbs. (11.3 kg) concentric load
Maximum Lateral Load: 20 lbs. (9.1 kg) @tip in retracted (minimum) position
Scale Resolution: 0.05" (1 mm)

THIS DRAWING IS THE PROPERTY OF HUNTINGTON MECHANICAL LABS, INC., AND IS PROPRIETARY IN GENERAL AND IN DETAIL. IT SHALL NOT BE MODIFIED IN ANY WAY. PERMISSION IS GIVEN TO PRINT AND DISSEMINATE FREELY.

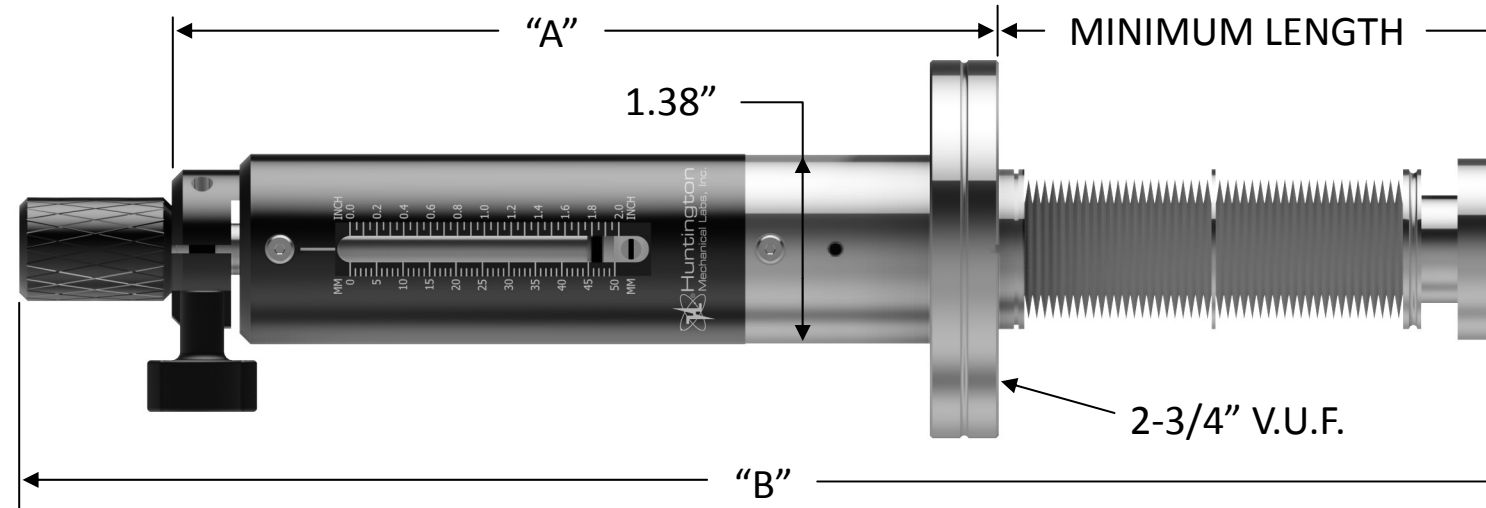

END VIEW

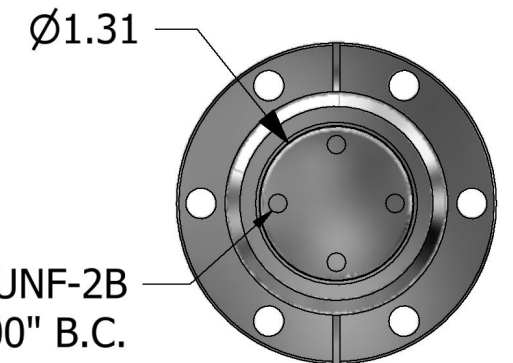

L-2221-X-SF Series



Dimensions: inches (mm)

L-SERIES LINEAR FEEDTHROUGH - PUSH/PULL ACTION

FLANGE	STROKE	LENGTH "A"	LENGTH "B"	MINIMUM LENGTH	WEIGHT (lbs.)	PART NUMBER
2 ³ / ₄ "	1.0 (25.4)	4.98 (126.5)	8.37 (212.6)	1.30 (33.0)	2.5	L-2221-1
	2.0 (50.8)	5.98 (151.9)	10.75 (273.1)	1.68 (42.7)	3.0	L-2221-2
	4.0 (101.6)	7.98 (206.7)	15.51 (394.0)	2.44 (62.0)	4.0	L-2221-4
KF 40	1.0 (25.4)	4.98 (126.5)	8.37 (212.6)	1.30 (33.0)	2.3	L-2221-1-SF
	2.0 (50.8)	5.98 (151.9)	10.75 (273.1)	1.68 (42.7)	2.8	L-2221-2-SF
	4.0 (101.6)	7.98 (206.7)	15.51 (394.0)	2.44 (62.0)	3.8	L-2221-4-SF

Other stroke lengths & flange options available. For quotes, please call 800-227-8059 or visit our website at www.huntvac.com. Email: vacman@huntvac.com

		13355 NEVADA CITY AVENUE GRASS VALLEY, CA. 95945
FEEDTHRU, LINEAR, 2000 SERIES PUSH-PULL, US STD. W/SCALE		
B	DWG. NO. L-2221-X-(SF) OUTLINE	REV. -
SCALE: NO SCALE	SHEET: 1	OF 1