

**Specifications**

**Sealing Mechanism:** Welded Bellows  
**Bakeout Temperature:** 300°C (Bellows only)  
**Operating Temp:** -20° to 230°C  
**Pressure Range:** Atmosphere To 1 x 10<sup>-11</sup> Torr

**Compact Z-Axis Manipulator**

Huntington's compact Z-axis series of manipulators allow for installations with limited space. Featuring a smaller outline and simplified designs these manipulators are simple, rugged and cost-effective. Compact manipulators feature 2 3/4" or 4 1/2" VAC-U-FLANGE® mounting in stroke lengths from 1 to 4". Operation is via a hand knob or 1/2" hex driver with visual positioning using an engraved scale. Edge welded stainless steel bellows and tapped VAC-U-FLANGES® create a robust envelope.

THIS DRAWING IS THE PROPERTY OF HUNTINGTON MECHANICAL LABS, INC., AND IS PROPRIETARY IN GENERAL AND IN DETAIL. IT SHALL NOT BE MODIFIED IN ANY WAY. PERMISSION IS GIVEN TO PRINT AND DISSEMINATE FREELY.

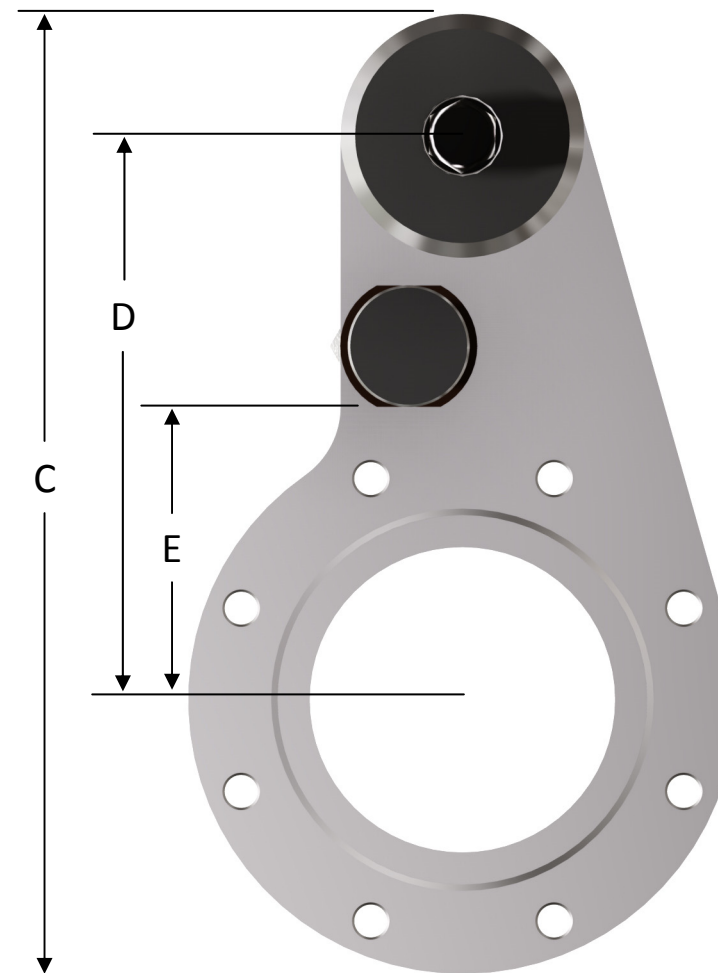
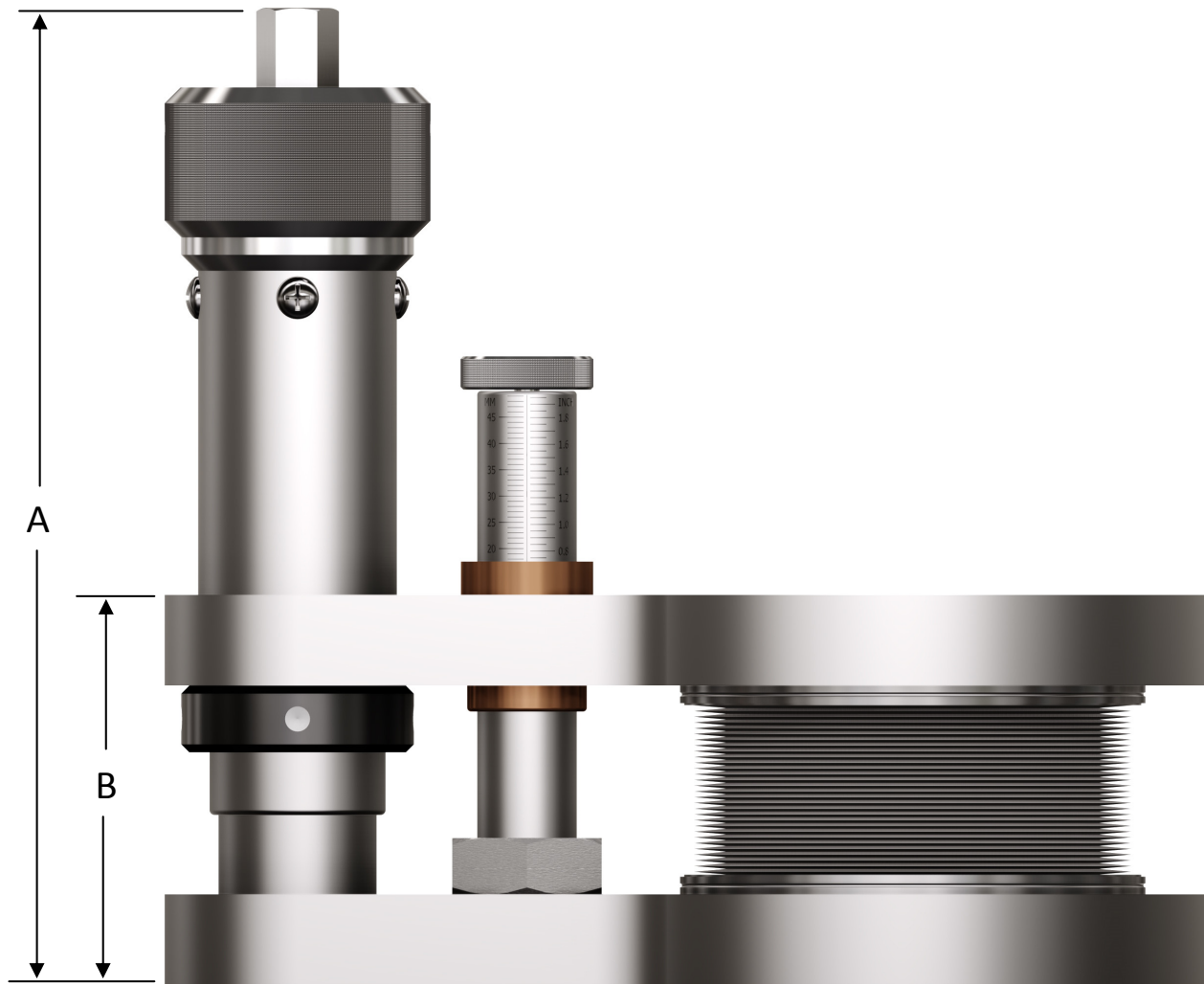

CMZ-275 SERIES

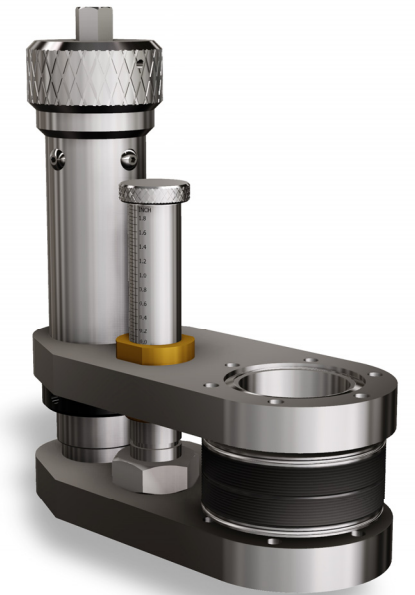

CMZ-450 SERIES

Dimensions: inches (mm)

**COMPACT Z-AXIS MANIPULATOR - VAC-U-FLANGE® (CF)**

FLANGE OD	STROKE	MINIMUM HEIGHT "A"	MINIMUM HEIGHT "B"	C	D	E	WEIGHT (lbs.)	PART NUMBER
2 3/4"	1.0	8.71	2.20	6.33	3.00	1.74	8.0	CMZ-275-1
	2.0	8.71	2.20	6.33	3.00	1.74	9.0	CMZ-275-2
	4.0	11.32	2.95	6.33	3.00	1.74	11.0	CMZ-275-4
4 1/2"	1.0	8.71	2.20	7.87	3.63	2.40	8.0	CMZ-450-1
	2.0	8.71	2.20	7.87	3.63	2.40	9.0	CMZ-450-2
	4.0	11.32	2.95	7.87	3.63	2.40	11.0	CMZ-450-4

*Other options available.*  
 For quotes, please call 800-227-8059  
 or visit our website at [www.huntvac.com](http://www.huntvac.com).  
 Email: [vacman@huntvac.com](mailto:vacman@huntvac.com)

		13355 NEVADA CITY AVENUE GRASS VALLEY, CA. 95945
<b>Z-AXIS MANIPULATOR,                  COMPACT DESIGN W/SCALE</b>		
<b>B</b>	DWG. NO. <b>CMZ-XXX-X OUTLINE</b>	REV. <b>-</b>
SCALE: NO SCALE	SHEET: 1	OF 1